K33-BLG/ELG

Sensor module for environment logging

Data Sheet and Manual

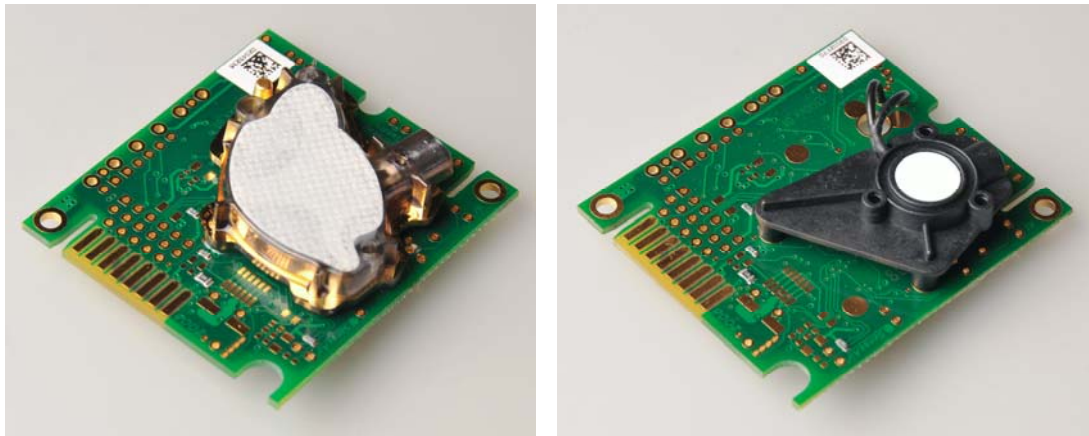

Figure 1 *CO₂Engine™ -ELG (left) and CO₂Engine™ -BLG (right)*

General

- This document describes a family of sensor modules *CO₂Engine™ - BLG/ELG* designed to measure and store records of environmental parameters such as
 - **Temperature**
 - **Relative Humidity**
 - **CO₂ concentration** (ELG up to 5000ppm range, BLG up to 30% range).
- The sensor module *CO₂Engine™ -BLG/ELG* is designed for battery powered operation with low average power consumption without compromising measurement precision and resolution.
- Virtual RTC (Real Time Clock) allows data and events logging with time stamps.
- Events include sensor power on, logging start/stop, ABC self calibration, user initiated zero and background calibrations.
- Reading of logger via I2C connector and SenseAir's I2C – USB bridge (SADK).
- I²C or UART communication can be used to read logged data for built in modules.

Use scenario *CO₂Engine™ - BLG/ELG*

CO₂Engine™ - BLG/ELG is a sensor module for CO₂ concentration, temperature and relative humidity. Sensirion's SHT11 Temperature / RH sensor is installed on the board to measure temperature and relative humidity.

There are three ways to activate measurement/logging

- Jumper (set AnIn1 high)

After power-on, sensor checks jumper presence, if jumper is not present (low level on input, AnIn1), sensor goes into sleep mode. If jumper is set (high level at input), sensor sleeps a predefined time (configured in EEPROM) and then start the measurement sequence. After measurement has been started the sensor wakes up periodically, makes measurements, stores result in on board non-volatile memory (if logger is activated) and goes into sleep mode until next measurement.

- Command "Force start measurement"

Another way to start/stop measurements is with the commands "Force Start Measurements" and "Force Stop Measurements", the sensor will act in the same way as if the jumper was set/reset.

- Command "Single measurement"

If only one measurement is desired the command "Single measurement" can be sent to the sensor. Then the sensor will measure once, store result in on board non-volatile memory (if logger is activated) and go back to sleep mode.

For correct timestamps sensors RTC has to be set after the sensor in powered. User can read logged data via serial port (UART with standard SenseAir cable) alternatively I2C-to-USB bridge.

For correct timing it is important that RTC is set after battery is inserted.

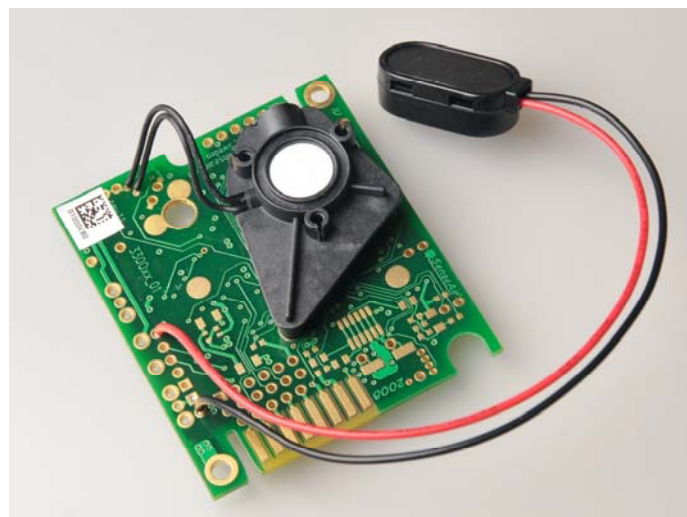

Figure 2 *CO₂Engine™ -BLG* powered via Vbat+

Drawings below show battery connection (with polarity) to the sensor (Vbat+), pin assignment of UART and I²C communication connectors.

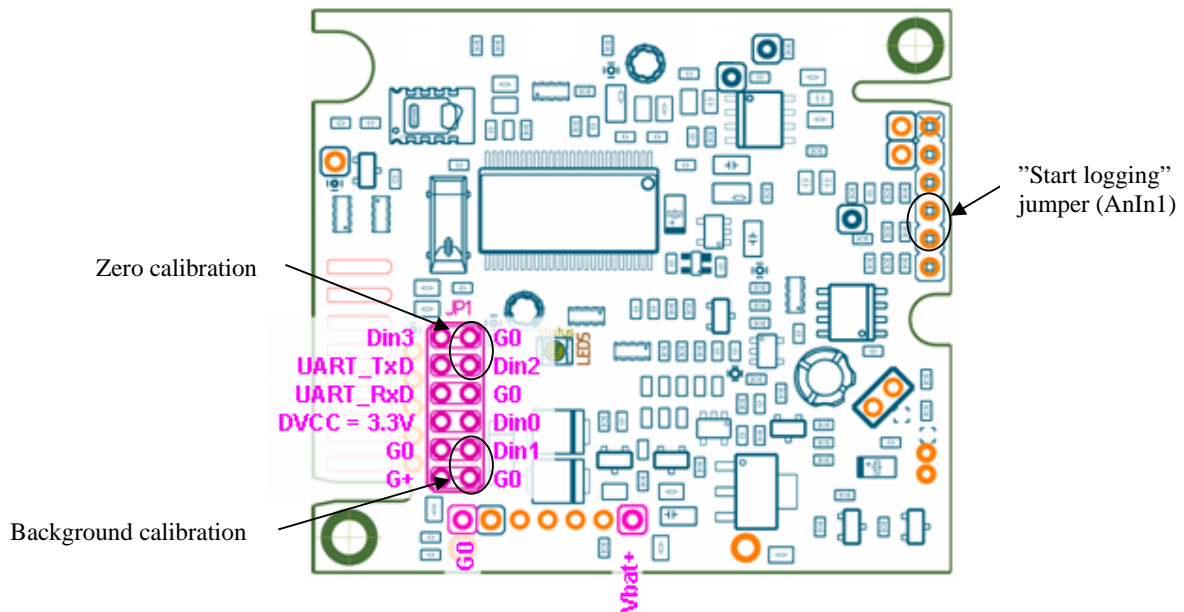

Figure 3 *CO₂Engine™ -BLG/ELG* powered via Vbat+ and data read via UART terminal.

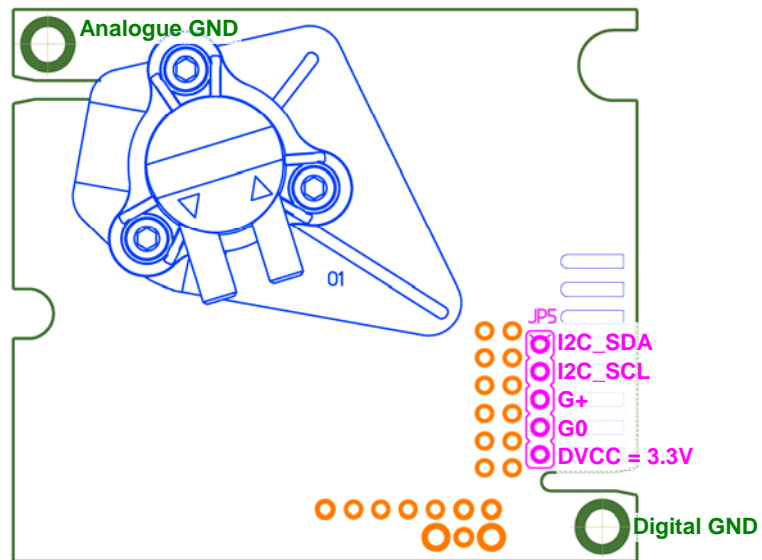

Figure 4 *CO₂Engine™ -BLG* with I²C terminal.

Terminal descriptions

Table below specifies what terminals and I/O options are available in the general **K33** platform (see also the layout picture Fig 3).

Functional group	Descriptions and ratings
Power supply	
G0	Power supply minus terminal Sensor's reference (ground) terminal
G+ Referred to G0:	Power supply via protection circuit. Protected by series 3.3R resistor and zener diode Absolute maximum ratings 5.5 to 12V, stabilized to within 10%
Vbat+ Referred to G0:	Power supply directly to the system without protection circuit. Absolute maximum ratings 4.75 to 12V, stabilized to within 10% Unprotected against reverse connection!
Communication	
UART (UART_TxD, UART_RxD)	CMOS physical layer, ModBus communication protocol. (refer "Modbus on CO2 Engine and eSense rev2_00.pdf" or later version for details) UART_RxD line is configured as digital input. Input high level is 2.1V min Input low level is 0.8V max UART_TxD line is configured as digital output. Output high level is 2.3V (assuming 3.3V DVCC) min. Output low level is 0.75V max UART_RxD input is pulled up to DVCC = 3.3V by 56 kOhm UART_TxD output is pulled up to DVCC = 3.3V by 56 kOhm ABSOLUTE MAX RATING G0 -0.5V DVCC + 0.5V
I2C extension. (I2C_SCL, I2C_SDA)	Pull-up to DVCC = 3.3V. (refer "I2C comm guide 2_10.pdf" or later version for details) ABSOLUTE MAX RATING G0 -0.5V DVCC + 0.5V

Continuation on the next page

Functional group	Descriptions and ratings
Digital I/Os, used as Inputs in standard configuration. May be implemented as jumper field	
Din0 Din1 Din2 Din3	<p>Digital switch inputs in standard configuration, Pull-up 56k to DVCC 3.3V. Driving it low or connecting to G0 activates input.</p> <p>Pull-up resistance is decreased to 4..10k during read of input or jumper. Advantages are lower consumption most of the time the input/jumper is kept low and larger current for jumpers read in order to provide cleaning of the contact.</p> <p>Din1 used for background calibration. Din2 used for zero calibration.</p>
AnIn1	Input set to DVCC activates measurement/logging cycle, input released (or held low) set sensor into sleep, in sleep mode sensor check AnIn1 and support communication.

*Table 1. I/O notations used in this document for the K33 platform with some descriptions and ratings. Please, beware of **the red colored texts that pinpoint important features** for the system integration!*

General PCB overview

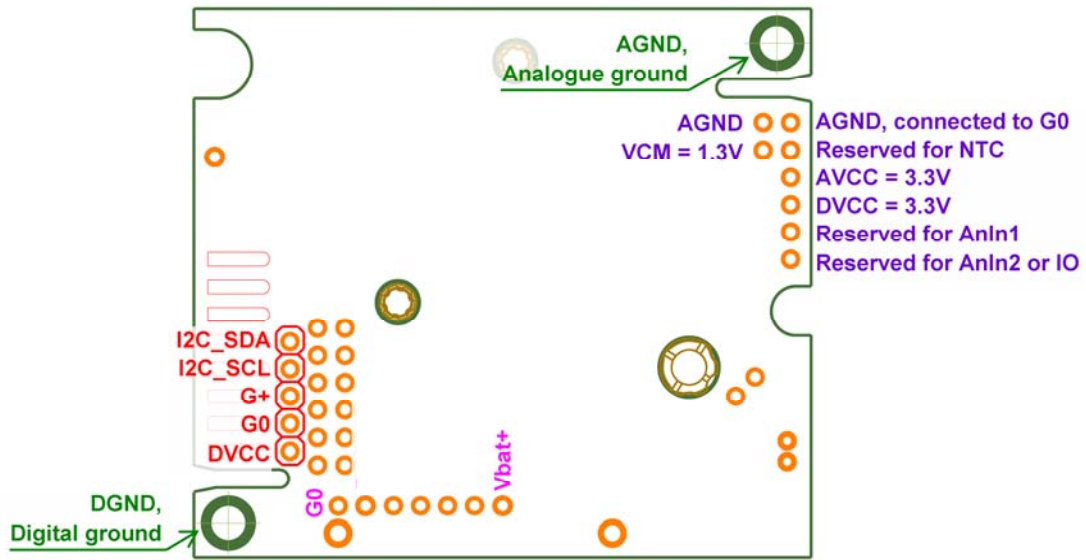

Figure 5 *CO₂Engine™ -BLG/ELG* I/O notations and terminals

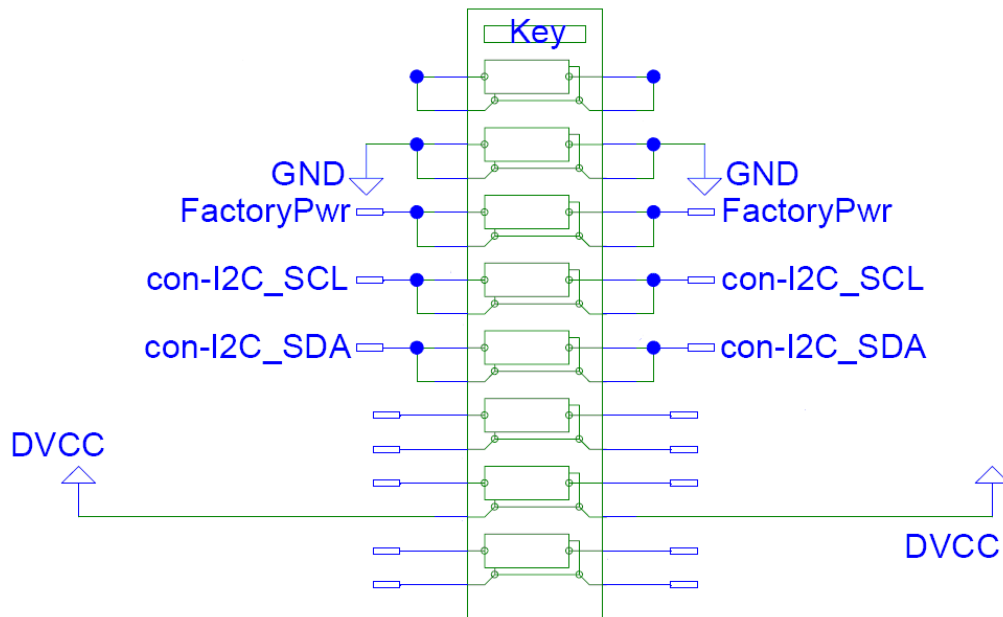

Figure 6 *CO₂Engine™ -BLG/ELG* edge connector, (seen from component side)

CO₂Engine™ BLG/ELG – Default appearance technical specification

General Performance:

Storage Temperature Range	-40 to +70 °C,
Storage Environment	Non condensing, non corrosive environment ²
Operating Temperature Range	0 to 50 °C
Operating Humidity Range	0 to 95% RH (non-condensing) ¹
Operating Environment	Non corrosive environment ² . Residential, commercial, industrial spaces used in HVAC (Heating Ventilation and Air-Conditioning) systems. ⁴
Sensor Life Expectancy	> 10 years
Maintenance Interval	Maintenance-free. See discussion of ABC algorithm on page 10.
Self-Diagnostics	complete function check of the sensor module
Conformance with the standards	RoHS directive 2002/95/EG

Electrical / Mechanical:

Power Input	6-12 VDC ³ max rating, stabilized to within 10% powering sensor via Vbat+ 6-14 VDC ³ max rating, stabilized to within 10% powering sensor via G+ (on board protection circuits)
Current Consumption	~250µA (1 measurement/hour) ~50µA in sleep ~60 mA average during active measurement sequence (~12s) < 150 mA peak current (averaged during IR lamp ON, 100 msec) < 250 mA peak power (during IR lamp start-up, the first 50 msec) for maximum operating time (if powered by batteries), choose batteries that can deliver 250mA pulses without large voltage drops (for example batteries recommended for cameras)
Electrical Connections	Vbat+, G+ and G0
Dimensions	51 x 57 x 14 mm (Length x Width x Height) for BLG (0..30% measurement range) 51 x 57 x 12 mm (Length x Width x Height) for ELG (0..5000ppm measurement range)

CO₂ Measurement:

Sensing Method	non-dispersive infrared (NDIR) waveguide technology with ABC, automatic background calibration algorithm (application specific)
Sampling Method	diffusion
Response Time (T _{1/e})	<25 sec gas diffusion time
Measurement period	5 min to 0.5 year interval, a measurement period less than 5 min can be used, but then specified accuracy on RH and temperature measurements are not guaranteed

ELG, CO₂ module 0..5000ppm:

Repeatability	± 20 ppm ± 1 % of measured value
Accuracy ⁵	± 30 ppm ± 3 % of measured value

BLG, CO₂ module 0..30%_{vol}:

Repeatability	± 0,1 %vol. CO ₂ ± 2 % of measured value
Accuracy ⁵	± 0,2 %vol. CO ₂ ± 3 % of measured value

Pressure Dependence + 1.6 % reading per kPa deviation from normal pressure, 100 kPa

On-board calibration support.....Din1 switch input to trigger Background Calibration @ 400 ppm (0.04%_{vol}) CO₂
Din2 switch input to trigger Zero Calibration @ 0 ppm CO₂

Note 1: Sensors are 100% tested in production at 45C / 85%RH / 1000ppm CO₂ for one hour. For applications operating continuously in high humidity, contact SenseAir for further information.

Note 2: SO₂ enriched environments are excluded.

Note 3: Notice that absolute maximum rating is 12V, so sensor can not be used with 12V+-10% supply.

Note 4: Different options exist and can be customized depending on the application. Please, contact SenseAir for further information!

Note 5: Accuracy is specified over operating temperature range at normal pressure 1013 mBar. Specification is referenced to certified calibration mixtures. Uncertainty of calibration gas mixtures (+-2% currently) is to be added to the specified accuracy for absolute measurements.

CO₂Engine™ BLG/ELG - Default appearance technical specifications (continued)

Temperature Measurement:

Sensor SHT11 from Sensirion (www.sensirion.com)
Measurement Range -40 to 60C
Accuracy^{6,7} ± 0.4C at 25C

Relative Humidity Measurement:

Sensor SHT11 from Sensirion (www.sensirion.com)
Measurement Range 0 to 100% RH non condensing
Accuracy^{6,7} ± 3% RH

Logger properties:

Logger Capacity 5400 logging points if CO₂ concentration, temperature and relative humidity are logged (with timestamp).

Logging Data Selectable, one data record can contain up to 14 bytes (max 4 variables)
Logging Period (1...255) * Measurement Period.
Delay since setting jumper 0 to 255 seconds (5s in default configuration)

Note 6: Specification is provided by Sensirion.

Note 7: Minimum 5 minutes measurement period.

Maintenance

The models based on **CO₂Engine™ K33** platform are basically maintenance free in normal environments thanks to the built-in self-correcting **ABC** algorithm.

ABC algorithm

The default sensor OEM unit is maintenance free in normal environments thanks to the built-in self-correcting **ABC algorithm** (*Automatic Baseline Correction*). This algorithm constantly keeps track of the sensor's lowest reading over a predefined period and slowly corrects for any long-term drift detected as compared to the expected fresh air value of 400 ppm CO₂.

Since timing (time between measurements) can be configured in BLG/ELG it is important to make sure that the sensor has possibility to measure "fresh air" during the predefined period.

It is recommended that ABC configuration is optimized for its tasks during a dialog between SenseAir and the OEM customer. In default configuration for BLG/ELG sensors ABC is switched off.

Calibration

Rough handling and transportation might, result in a reduction of sensor reading accuracy. For post calibration convenience, in the event that one cannot wait for the ABC algorithm to cure any calibration offset, two switch inputs Din1 and Din2 are defined for the operator to select one out of two prepared calibration codes. If Din1 is shorted to ground during a measurement cycle (flashing lamp), the internal calibration code **bCAL** (*background calibration*) is executed, in which case it is assumed that the sensor is operating in a fresh air environment (400 ppm CO₂). If Din2 is shorted instead during a measurement cycle (flashing lamp), the alternative operation code **zCAL** (*zero calibration*) is executed in which case the sensor must be purged by some gas mixture free from CO₂ (i.e. Nitrogen or Soda Lime CO₂ scrubbed air).

Make sure that the sensor environment is steady and calm during calibration!

Input Switch Terminal <i>(normally open)</i>	Default function <i>(when closed for minimum 8 seconds)</i>
Din1	bCAL (background calibration) assuming 400 ppm CO ₂ sensor exposure
Din2	zCAL (zero calibration) assuming 0 ppm CO ₂ sensor exposure

Table II. Switch input default configurations for **CO₂Engine™ K33**

Self-diagnostics

The system contains complete self-diagnostic procedures. A full system test is executed automatically every time the power is turned on. In addition, constantly during operation, the sensor probes are checked against failure by checking the valid dynamic measurement ranges. All EEPROM updates, initiated by the sensor itself, as well as by external connections, are checked by subsequent memory read back and data comparisons. These different system checks return error bytes to the system RAM. If this byte is not zero, the logic output terminal **Status** will be put into Low level state. The full error codes are available from the UART port or via I²C communication. *Offset regulation error* and *Out of Range* are the only bits that are reset automatically after return to normal state. All other error bits have to be reset after return to normal by UART/I2C overwrite, or by power off/on.

Error code and action plan (error code can be read via one of communication channels)

Bit #	Error code	Error description	Suggested action
0	1	Fatal Error	Try to restart sensor by power OFF/ON. Contact local distributor.
1	2	Offset regulation error	Try to restart sensor by power OFF/ON. Contact local distributor.
2	4	Sensirion com error Unable to communicate with Sensirion (Temp/RH) sensor.	Try to restart sensor by power OFF/ON. Check detailed settings and configuration with software tools. Contact local distributor.
3			
4	16	DetTemp out of range. Indicate high (out of range) detector temperature.	
5	32	CO2 out of range Indication of high (out of range) CO2 level.	
6	64	Memory error Error during memory operations.	
7	128	Sensirion space temp out of range	

Table III. Switch input default configurations for *CO₂Engine™ K33*

Remark: If several errors are detected at the same time the different error code numbers will be added together into one single error code!